

BALANCED
ERGONOMIC
COMPACT
RELIABLE
VERSATILE
SECURE

Innovative Medical Designs' products simplify the work of nurses and physicians in the OR, ICU, ER and related areas. Our designs are developed in close cooperation with physicians and nurses. As a result they have unmatched reputation for superior ergonomic and clinical performance.

BALANCED

All axis of movement are through the center of gravity for a balanced operation

VERSATILE

Carries virtually every flatpanel used in OR, ICU and ER

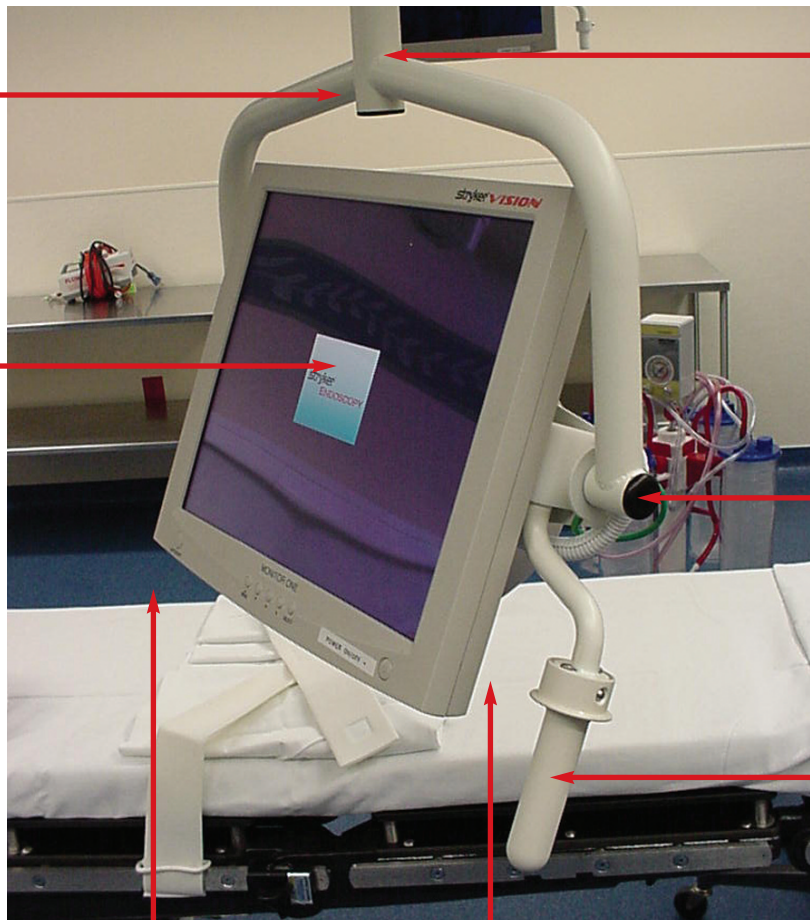

RELIABLE

Video and electrical connections enclosed, safe and secure

ERGONOMIC

Free tilt positioning to "full flat" reducing neck strain

SECURE

Adjustable compression brakes for fingertip control

COMPACT

Creates more space for surgical team

Hi-Beam Flatpanel Carriers streamline the design of the Cath Lab, OR and ICU with product features such as:

- Suspension solutions to hold from one to six monitors on one ceiling arm
- Suspended work cells for entire personal computers
- Easy to position platforms for optimal viewing
- Excellent strength to weight ratio with reliable robust design
- Concealed video and electrical connections for protection and security
- Ability to mount to all manufacturers flatpanels and all Ondal suspension arms



Model FPY-0001 Single 19" Carrier

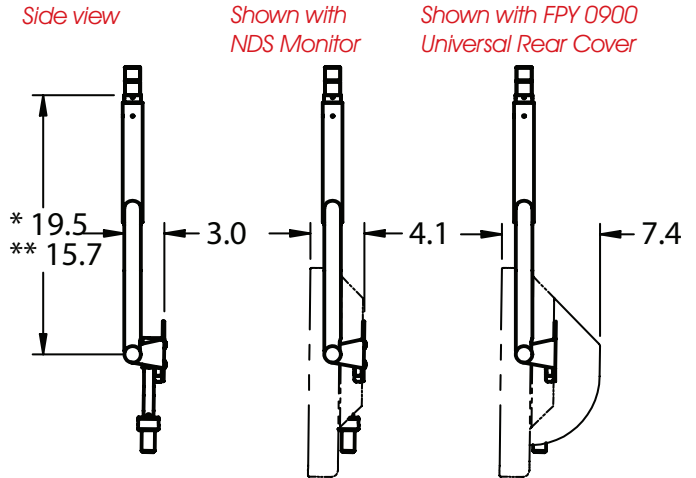
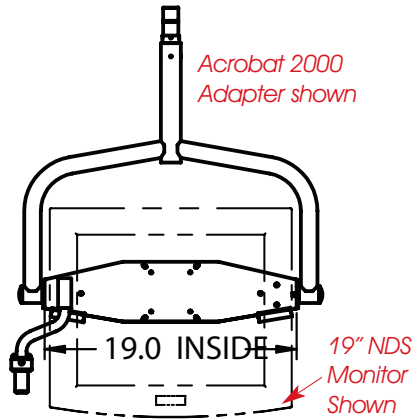

Model FPY-0021 Single 23" Carrier

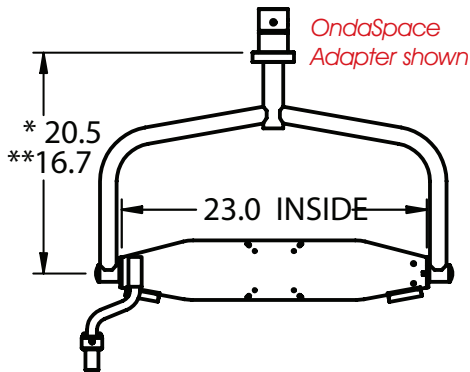

Model FPY-0027 Single 24" Carrier

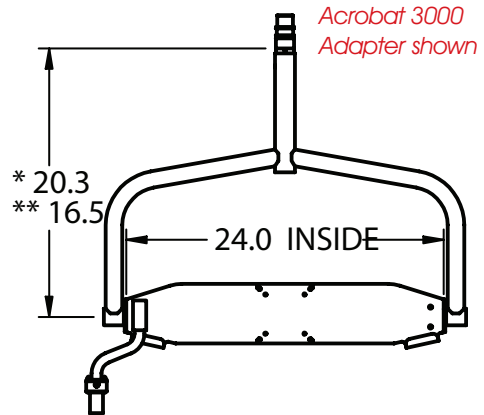

Model FPY-0030 Single 26" LED Carrier

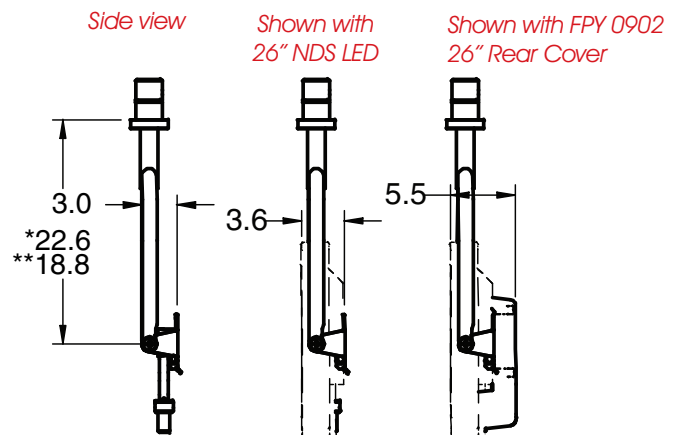
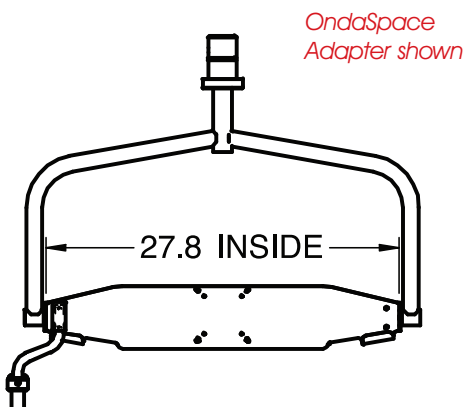

* Acrobat 2000 & 3000
** OndaSpace

Model FPY-0024 Single 32" Carrier

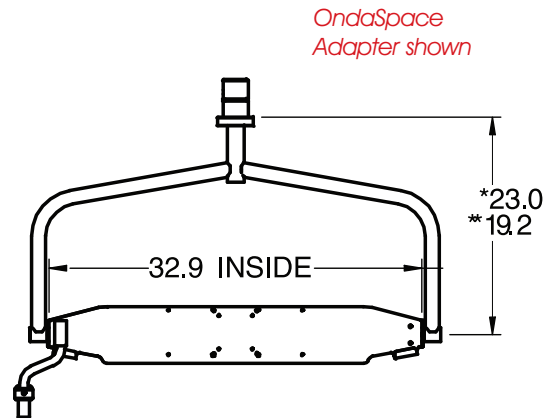

Model FPY-0032 Single 42" Carrier

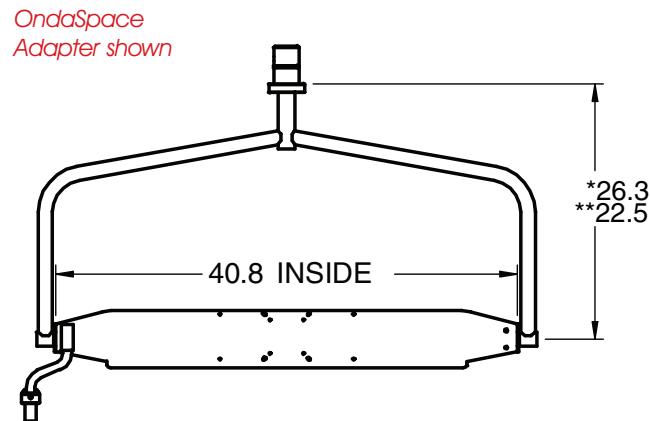

Model FPY-0003 Dual Carrier

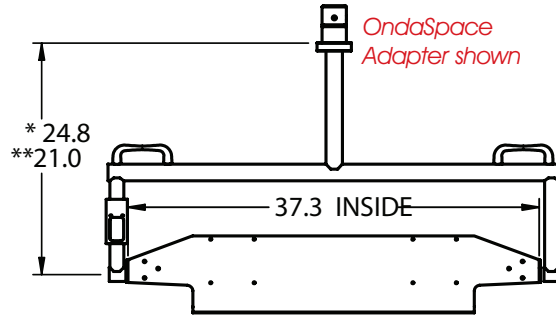

Model FPY-0004 Dual Independent Tilt Carrier

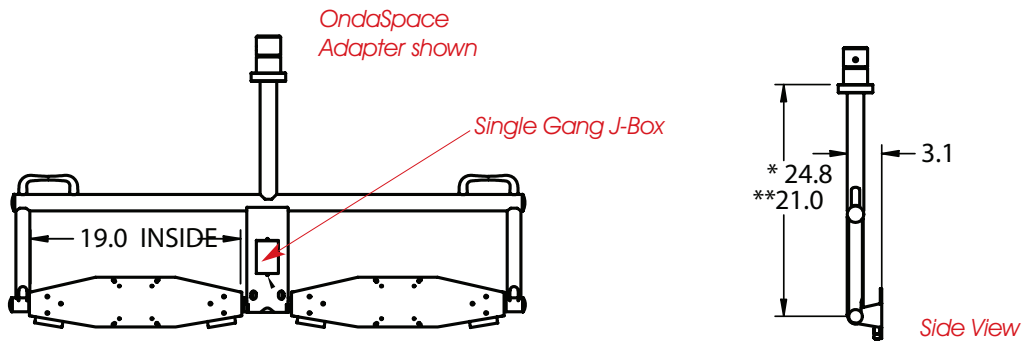

Model FPY-0022 Dual Independent Tilt 23" Carrier

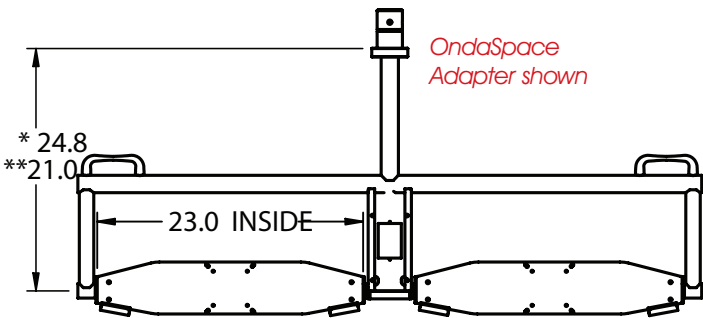

Model FPY-0026 Dual Independent Tilt 26" Carrier

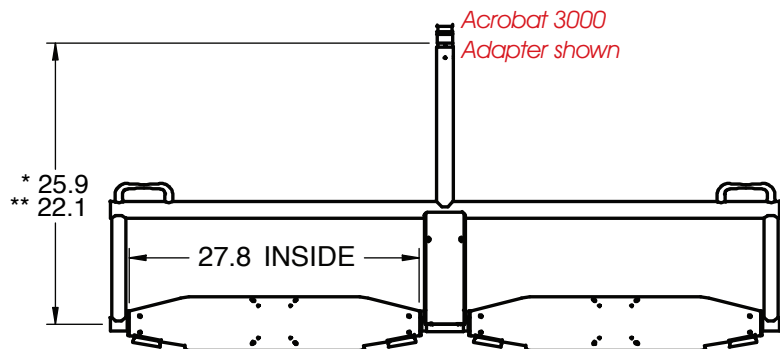

* Acrobat 2000 & 3000
** OndaSpace

Model FPY-0033
Dual 26" Over/Under Carrier

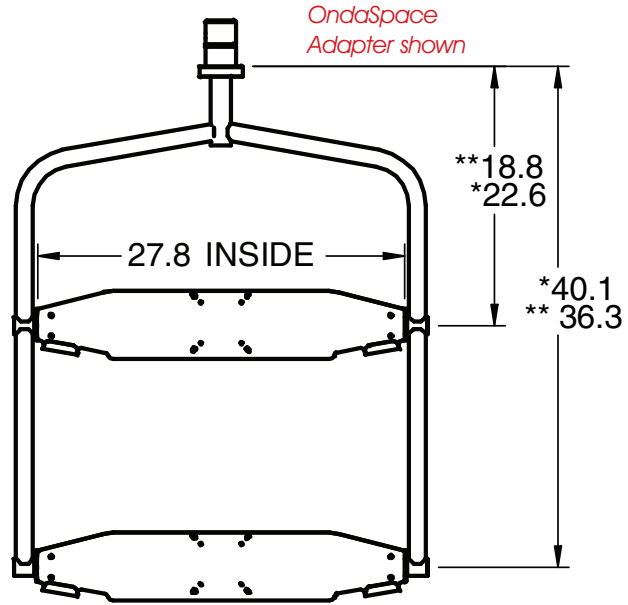

Model FPY-0017
Triple Carrier Landscape

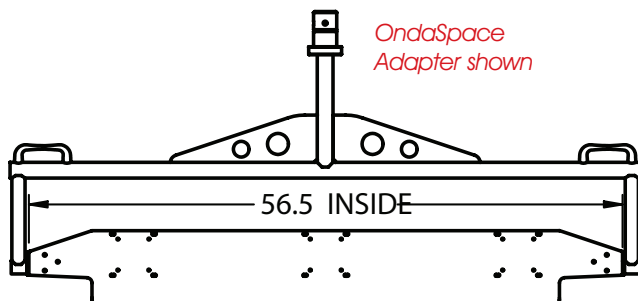

Model FPY-0009
Quad Carrier

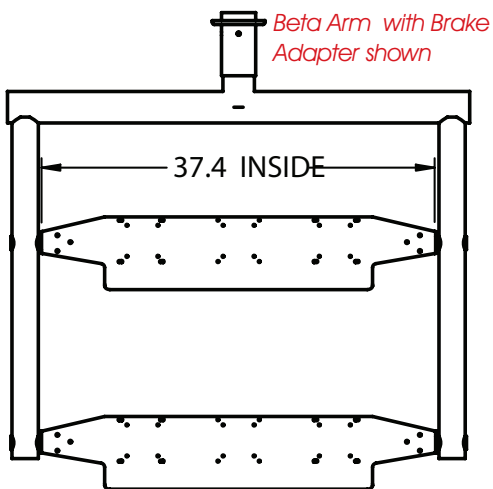

Model FPY-0010
Hexa Carrier

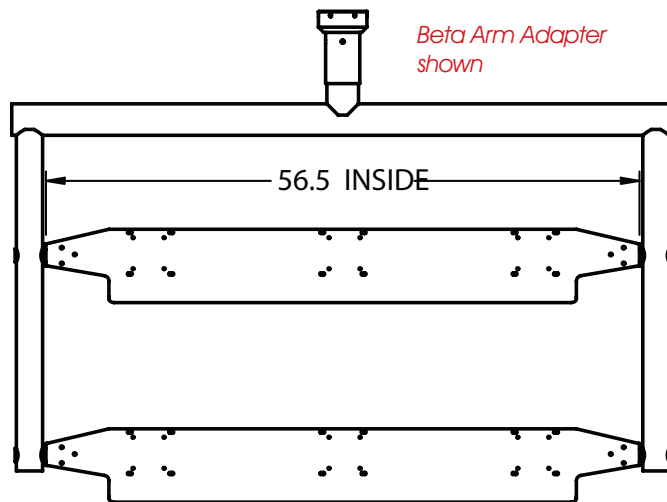

Model FPY-0902 26" Rear Cover NDS

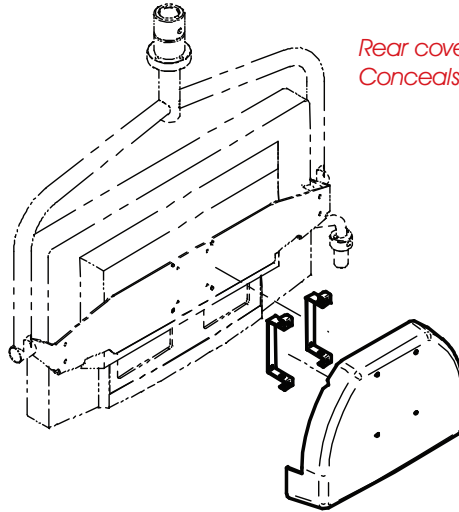

Rear cover fits 26" and 32" NDS.
Conceals cables, connectors and power supply.

Model FPY-0001.1 Flatpanel Rotation

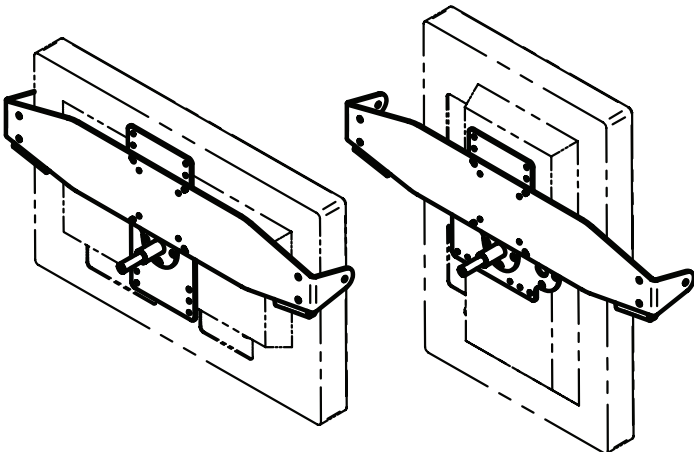

Landscape-to-portrait
Field retrofitable

Model FPY-0001.2 Slider Plate

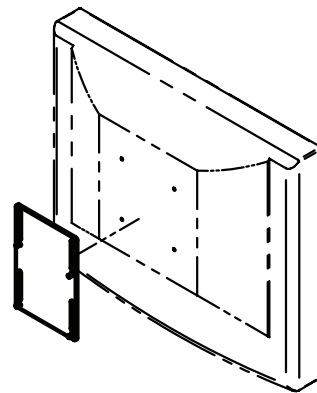

Slider Plate
Nest an array of flatpanels
Field retrofitable

Model FPY-0007 PC Carrier

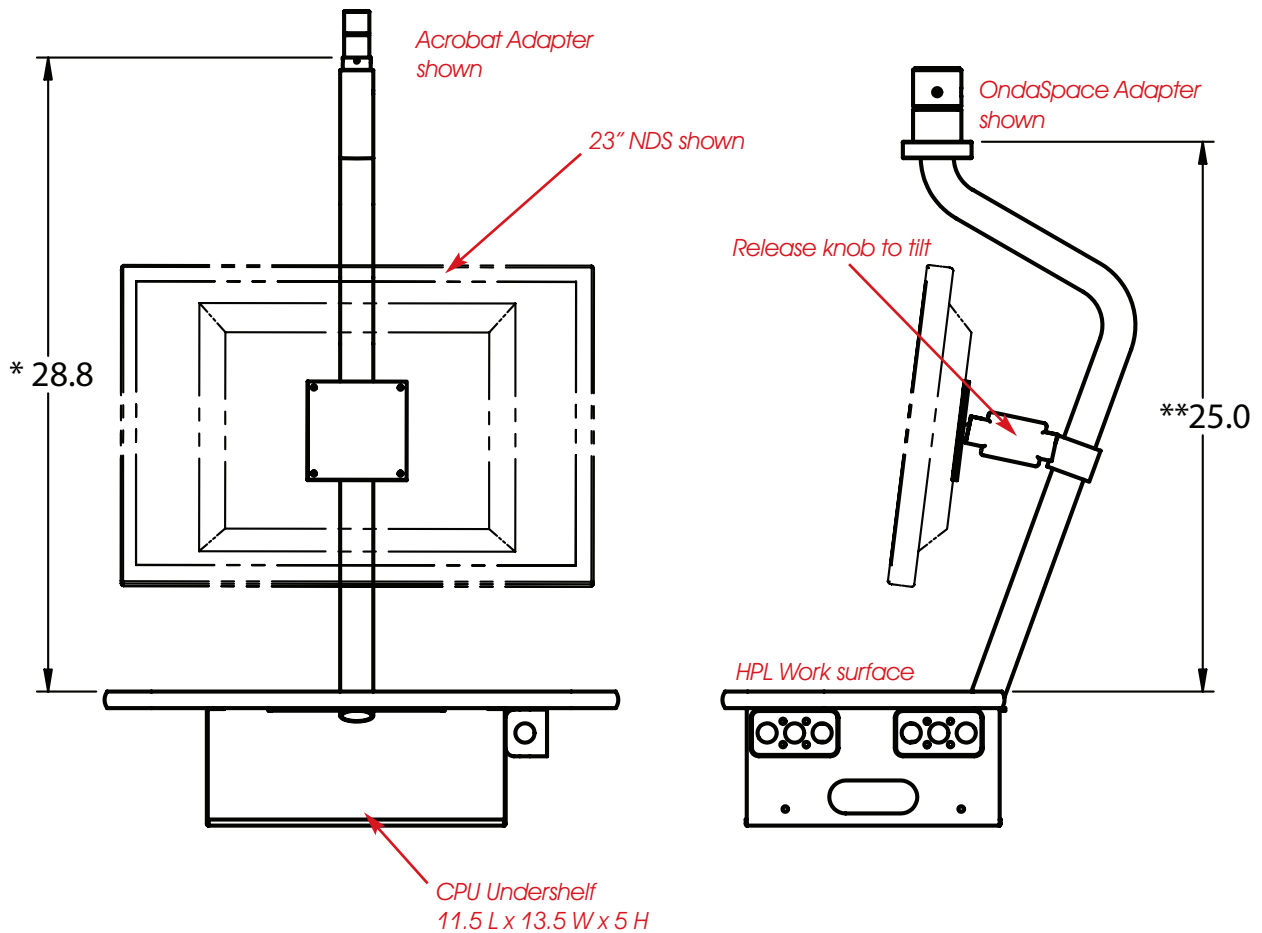
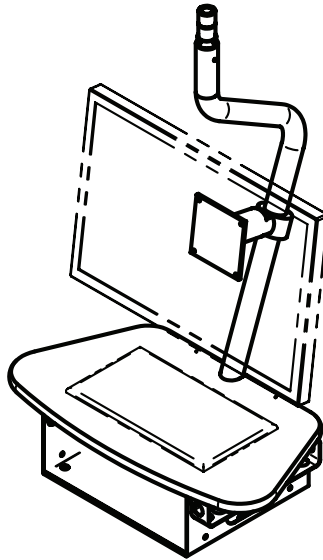

* Acrobat 2000 & 3000
** OndaSpace

Model FPY-0023 Single Flatpanel Gimble

OndaSpace Adapter
shown

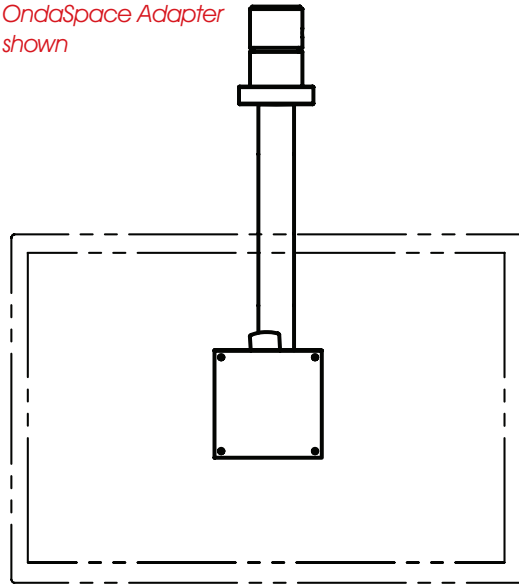

23" NDS Shown

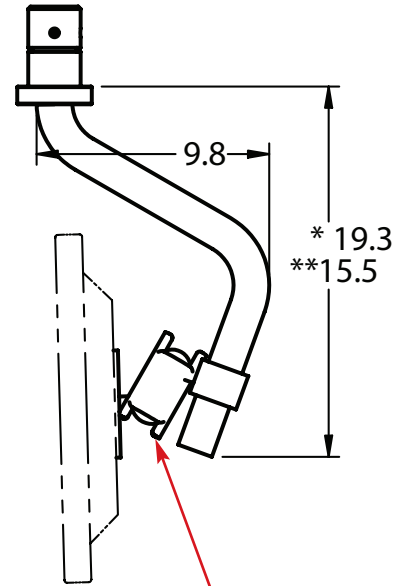

Release knob to tilt

	PRODUCT NUMBERS - SINGLE CARRIERS						CABLE BUNDLE
	FPY-0001	FPY-0021	FPY-0027	FPY-0030	FPY-0024	FPY-0032	
MONITOR CAPACITY in (diagnosl veivable)	21	23	24	26	32	42	
SUSPENSION SYSTEM TYPE							
ACROBAT AC 2000	X	X	X	X			3/4"
ACROBAT AC 3000	X	X	X	X	X	X	1"
ONDASPACE	X	X	X	X	X	X	1 3/8"
BETA	X	X	X	X	X	X	3"
BETA SPRING	X	X	X	X	X	X	3"
FEATURES							
REAR FLATPANEL COVER (optional)			X	X	X		
STERILE HANDLE POST (standard)	X	X	X	X	X	X	
ADDITIONAL STERILE HANDLE POST (optional)	X	X	X	X	X	X	
CARRIER WEIGHT lbs. (empty)	10	14	14	15	16	18	

	PRODUCT NUMBERS - DOUBLE CARRIERS									CABLE BUNDLE	
	FPY-0004	FPY-0022	FPY-0026	FPY-0023	FPY-0033	FPY-0017	FPY-0009	FPY-0010	FPY-0007		
MONITOR CAPACITY in (diagnosl veivable)	23	24	26	UP TO 32	26	21	21	21	UP TO 26		
SUSPENSION SYSTEM TYPE											
ACROBAT AC 2000										X	3/4"
ACROBAT AC 3000	X	X	X	X	X					X	1"
ONDASPACE	X	X	X	X	X	X				X	1 3/8"
BETA	X	X	X	X	X	X	X	X	X	X	3"
BETA SPRING	X	X	X	X	X	X	X	X	X	X	3"
FEATURES											
REAR FLATPANEL COVER (optional)			X	X	X						
STERILE HANDLE POST (optional)	X	X	X		X	X	X	X			
CARRIER WEIGHT lbs. (empty)	21	23	28	4	28	23	44	64	13		

Technical data:

Type	ACROBAT® 2000	Electricity - non-stop	<ul style="list-style-type: none"> 3-pole coupler: 230 V, 16 Amp. 5-pole coupler: 230 V, 16 Amp. 2 signal contacts 50 mA - 2 A 5-24 V 7-pole coupler: 230 V, 16 Amp. 4 signal contacts 50 mA - 2 A 5-24 V 9-pole coupler: 230 V, 16 Amp. 6 signal contacts 50 mA - 2 A 5-24 V
Model	Ceiling and wall mounted	with stop	
Load max.	21 kg or 2 x 18 kg with Ceiling duo	Fixing	
Weight ranges	1.5-3.5 / 3.5-7 / 3-6 / 7-12 / 8-13 / 9-15 12-18 / 13.5-21 kg		
Extension arms	750 or 950 mm		
Initiating force at Features	≤ 2N adjustable upper motion limit, exact parallel guidance, comfortable weight adjustment		
Tensile safety factor	4-times total load against yield strength according to EN 60601		
Mark of conformity	CE		
Test symbol	UL		
Colours	RAL 9002, 9010, (other colours on request)		Brackets, connection elements or individual adapter elements for equipment

Ceiling duo

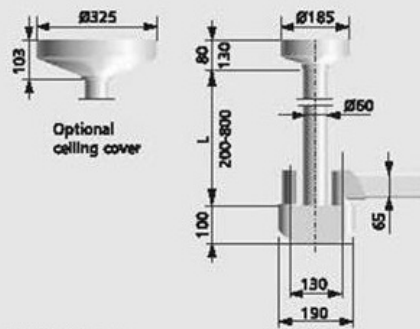

Ceiling flanges

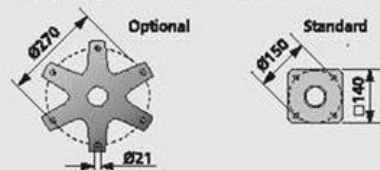

Ceiling single

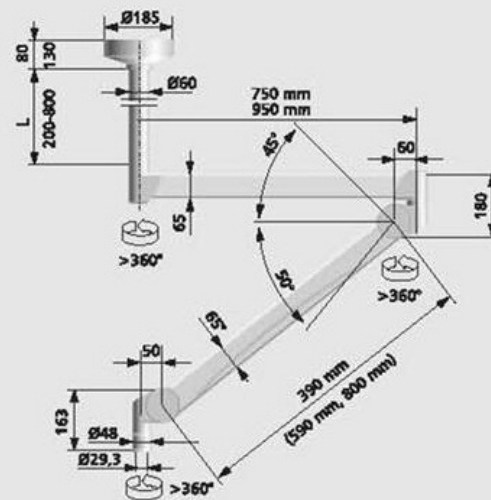

Wall

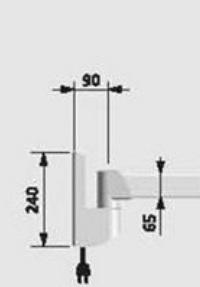

Wall flange

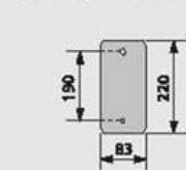

All dimensions in mm

System overview:

Ceiling-mounted unit:

for spring arm
weight 10 kg



for extension arm plus spring arm
weight single 10 kg / duo 12 kg



Single



Duo

Wall-mounted unit:

for spring arm
weight 2 kg



for extension arm plus spring arm
weight 2 kg



Extension arm for wall- and ceiling-mounted unit

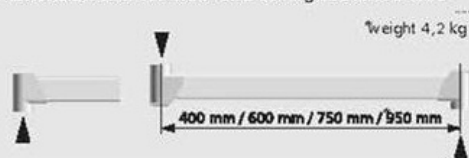

Spring arm with parallel guidance or straight condition

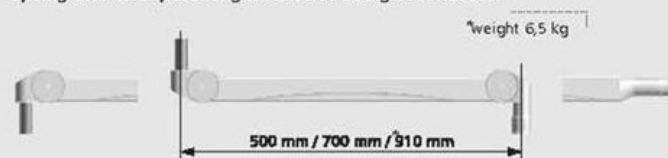

Technical datas:

Type	OndaSpace®	ACROBAT® 3000
Model	Ceiling and wall mounted version	Ceiling and wall mounted version
Payloads	8-15 kg / 15-32 kg / 30-40 kg	7-11 kg / 12-18 kg / 17-30 kg
Electric	3- or 5-pole rotation commutator	3- or 5-pole rotation commutator
with rotational stop	Cable installation possible	Cable installation possible
Cable routing	450 mm ²	384 mm ²
Cable equipment	Examples for max. equipment: 2 cable each Ø 12 mm plus 2 cables each Ø 6,5 mm	Examples for max. equipment: 1 cable Ø 9 mm plus 1 cable Ø 6 mm plus 2 cables each Ø 5 mm
Colours	RAL 9002, RAL 9010	RAL 9002, RAL 9010
Certificates	VDE, CE, UL	VDE, CE, UL

Basic components ceiling mount:

Ceiling plate:

Ceiling mount for spring arm

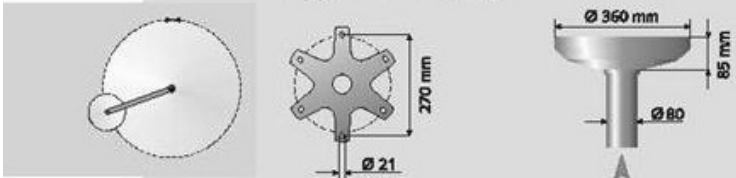

Ceiling mount for extension and spring arm

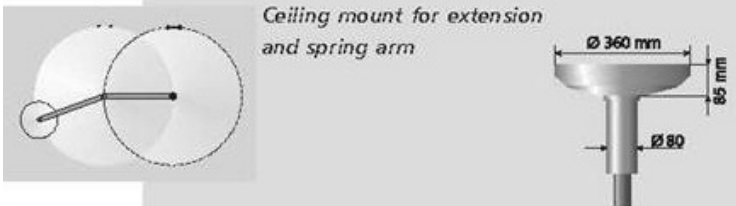

Extension arm for ceiling mount:



Basic components wall mount:

Wall mount:

Wall mount for spring arm



Wall mount for extension and spring arm



Extension arm for wall mount:

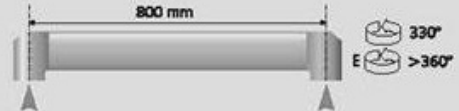

OndaSpace® Spring arm

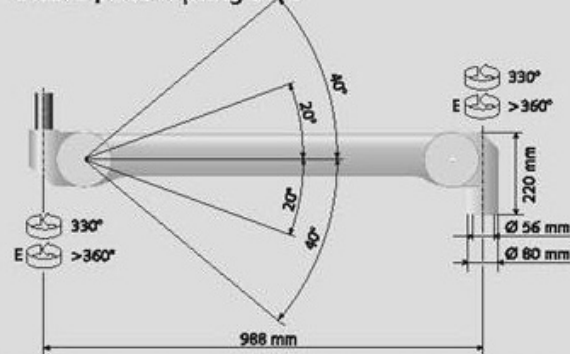

ACROBAT®3000 Spring arm

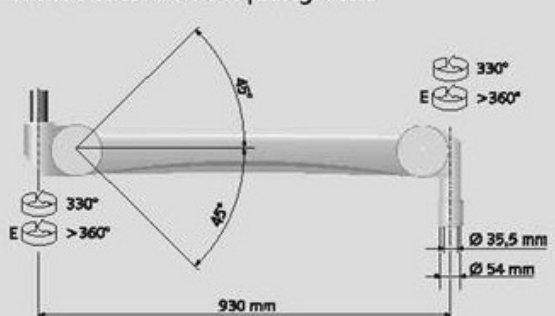

Additional to this program, we are able to deliver service heads, e-boxes, monitor yokes and TFF-Adapters.